

**REPLACEMENT PARTS**

Supersedes: SEE BELOW

e | 530.18-RP5.2YI (596)

SUPERSEDES: 530.18-RP2.13YI (1192), ERRATA 1 (595) PAGE 6.  
NOTE: FOR STYLE "B" THRU "D" MODELS SEE PAGE 6.

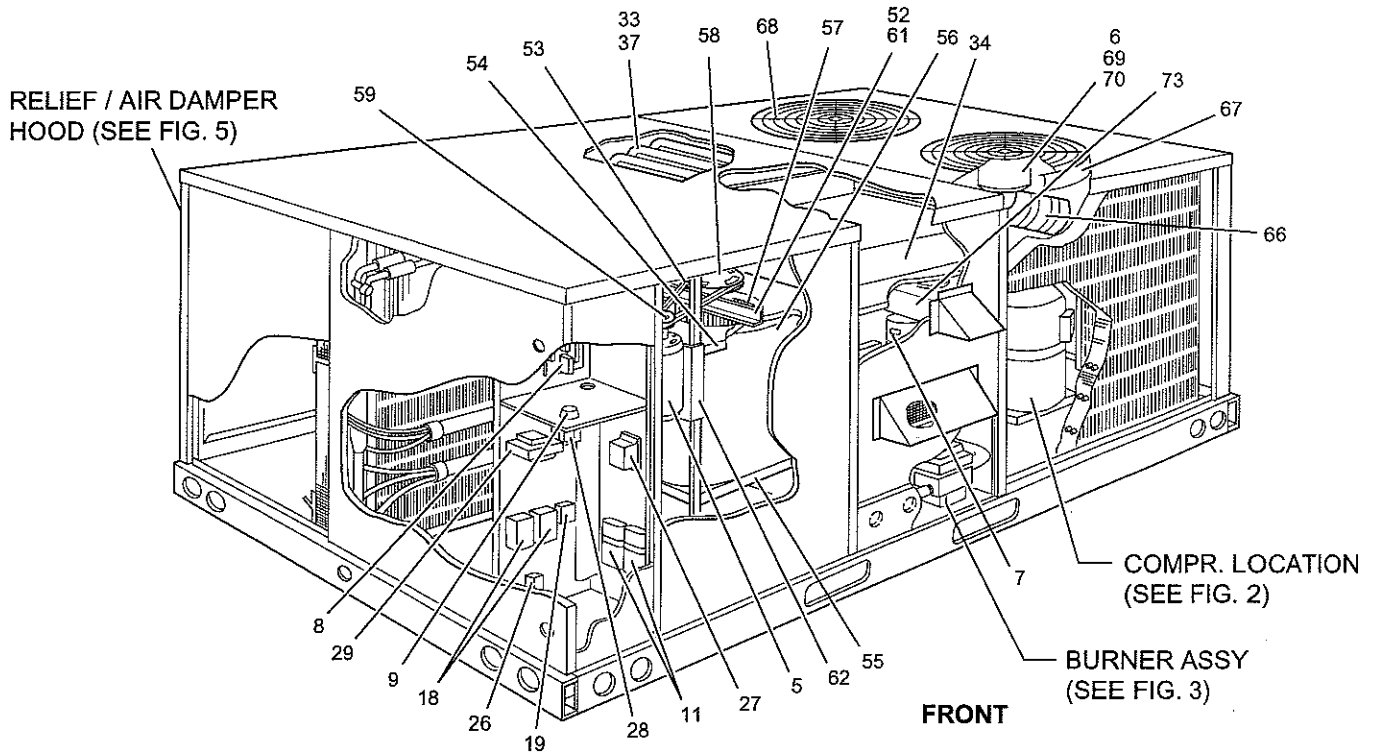

**FIG. 1 – SINGLE PACKAGE GAS / ELECTRIC UNIT**

**COMPRESSORS**

FIG	ITEM	DESCRIPTION	D2CG120N16550A
			5-BURNER
2	(1)	COMPR., HERMETIC (BRISTOL-2 REQ'D) (1)	015-02192-702
2	(1)	COMPR., HERMETIC (COPELAND-2 REQ'D) (1)	015-02401-005
2		SPACE FOR FUTURE PARTS ADDITIONS	
2	3	ISOLATOR, COMPRESSOR (8-REQ'D)	028-07772-000
4		SPACE FOR FUTURE PARTS ADDITIONS	

**MOTORS**

FIG	ITEM	DESCRIPTION	D2CG120N16550A
			5-BURNER
1	(5)	MOTOR, BLOWER (3.0 HP)	024-19623-020
1	(6)	MOTOR, FAN (2-REQ'D)	024-24110-702
1	(7)	MOTOR, VENTOR (2)	024-24115-712

**ELECTRICAL**

FIG	ITEM	DESCRIPTION	D2CG120N16550A
			5-BURNER
1	8	BOARD, CIRCUIT	031-00652-700
1	9	BREAKER, CIRCUIT [CB]	024-24055-000
*	10	BOOT RUBBER CAPACITOR	028-04133-000

\* NOT SHOWN

(1) CUSTOMER MUST IDENTIFY VENDOR WHEN ORDERING COMPRESSOR.  
(2) INCLUDES CENTRIFUGAL SWITCH.

Major components and suggested stocking items are shown with item number in parenthesis "( )".

**ELECTRICAL (Cont.)**

FIG	ITEM	DESCRIPTION	D2CG120N16550A
			5-BURNER
1	(11)	CAPACITOR, RUN (7.5MFD/370V) [1,2RC]	024-20045-700
*	12	CONNECTOR, CAP (3-CIRCUIT)	025-21193-000
*	13	CONNECTOR, CAP (6-CIRCUIT)	025-20963-000
*	14	CONNECTOR, CAP (9-CIRCUIT)	025-21191-000
*	15	CONNECTOR, PLUG (3-CIRCUIT)	025-19671-000
*	16	CONNECTOR, PLUG (6-CIRCUIT)	025-19670-000
*	17	CONNECTOR, PLUG (9-CIRCUIT)	025-21192-000
1	(18)	CONTACTOR (2-REQ'D) [1,2M]	024-18056-702
1	(19)	CONTACTOR [3M]	024-25838-700
	20	CONTACT, SOCKET (4)	025-25586-000
*	21	CONTACT, SOCKET (5)	025-19673-000
*	(22)	CONTROL, PRESSURE	025-17620-014
*	(23)	CONTROL, TEMPERATURE (3) [FS]	025-27727-001
*	24	HOUSING, SINGLE LEAF (16 CIRCUIT)	025-26364-000
*	25	LABEL, WIRING (REFERENCE)	035-11236-000
1	26	LUG, GROUND	025-18094-000
1	(27)	RELAY, CONTROL [DMR]	024-21678-700
1	(28)	RELAY, CONTROL (HEAT SEQUENCE) [TDR]	024-19082-028
1	(29)	TRANSFORMER [1T]	025-27732-700
	30	SPACE FOR FUTURE PARTS ADDITIONS	
	31	SPACE FOR FUTURE PARTS ADDITIONS	

**GAS HEAT SECTION**

FIG	ITEM	DESCRIPTION	D2CG120N16550A
			5-BURNER
*	32	BAFFLE, AIR (PLATE)	063-92587-000
1	33	BAFFLE, AIR (HEAT EXCH. TUBE) 1 PER TUBE	063-90071-000
1	34	BOX, FLUE (TOP & FRONT)	063-89949-000
3	35	BURNER, GAS (5-REQ'D)	029-18431-000
3	36	CROSSOVER, GAS	073-07782-002
1	37	HEAT EXCHANGER	363-90016-003
3	38	MANIFOLD, GAS	029-20073-000
*	39	SUPPORT, BURNER ( FRONT ANGLE BRACE)	063-92490-000
3	40	SUPPORT, BURNER (L/H SIDE & REAR)	063-90005-002
3	41	SUPPORT, BURNER (R/H SIDE)	063-92594-000
3	42	ORIFICE, GAS BURNER #32 (5-REQ'D)	029-20423-032
3	43	ORIFICE, GAS PILOT #56	029-20422-056
	44	SPACE FOR FUTURE PARTS ADDITIONS	

**GAS/ELECT. CONTROLS**

FIG	ITEM	DESCRIPTION	D2CG120N16550A
			5-BURNER
*	45	CONTROL, TEMPERATURE (LIMIT)	025-26366-003
*	46	CONTROL, TEMPERATURE (ROLLOUT)	025-26392-003
*	(47)	MODULE, IGNITION CONTROL [IC]	025-29012-700
3	(48)	IGNITOR, SPARK	025-29010-000
3	(49)	SENSOR, FLAME	025-29011-000
3	(50)	VALVE, GAS (WHITE RODGERS)	025-26373-700
	51	SPACE FOR FUTURE PARTS ADDITIONS	

\* NOT SHOWN

(3) USE HEAT CONDUCTIVE COMPOUND 013-02250-000 WHEN APPLYING CONTROL TO SUCTION LINE.

(4) USE HAND TOOL #044-02998-700 WHEN APPLYING CONTACT.

(5) USE HAND TOOL #044-02999-700 WHEN APPLYING CONTACT.

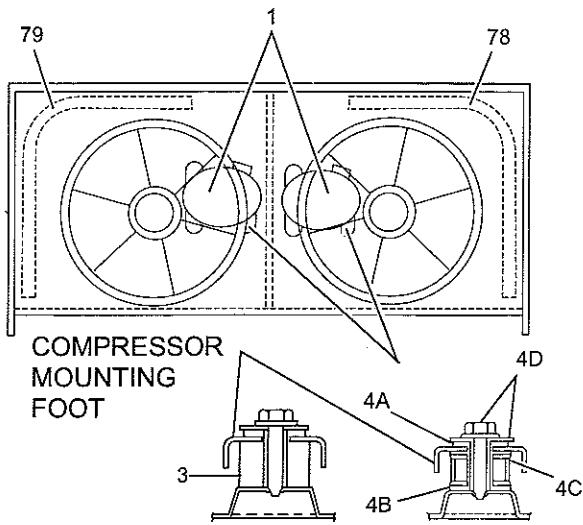

FIG. 2 - COMPRESSOR & COIL SECTION

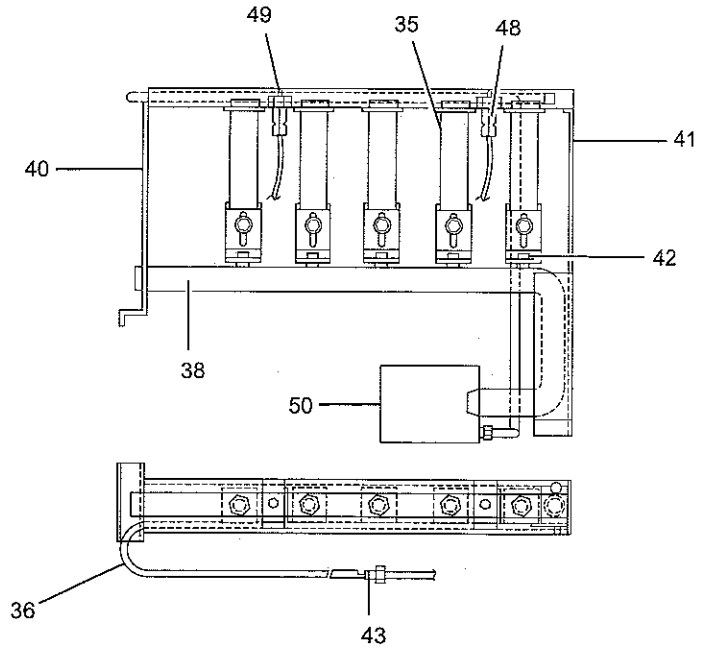

FIG. 3 - BURNER ASS'Y

**AIR MOVING (BLOWER)**

FIG	ITEM	DESCRIPTION	D2CG120N16550A
			5-BURNER
1	52	BEARING, BALL (PILLOW BLOCK) (2-REQ'D)	029-20424-700
1	53	BELT, "V" (A56)	028-07430-000
1	54	PLATE, HOUSING (TOP)	063-89998-000
1	55	PLATE, HOUSING (BOTTOM)	063-89999-000
1	56	HOUSING, BLOWER (W/O WHEEL)	063-89951-000
1	57	WHEEL, BLOWER	026-25529-002
1	58	PULLEY, FIXED (BLOWER)	028-10564-000
1	59	PULLEY, VARIABLE (MOTOR)	028-04763-700
*	60	SHAFT, BLOWER	001-07115-000
1	61	SUPPORT, BEARING (2-REQ'D)	063-89950-000
1	62	SUPPORT, MOTOR	063-89938-000
*	63	KEY, STEEL 1/4 SQ X 2" LG (FIXED PULLEY)	001-07110-005
*	64	KEY, STEEL 1/4 SQ X 6-3/8" LG (WHEEL)	001-07110-004
	65	SPACE FOR FUTURE PARTS ADDITIONS	

**AIR MOVING (COND. FAN)**

FIG	ITEM	DESCRIPTION	D2CG120N16550A
			5-BURNER
1	(66)	BLADE, FAN (2-REQ'D)	026-25511-000
1	67	ORIFICE, FAN (2-REQ'D)	063-89756-000
1	68	GUARD, FAN (2-REQ'D)	026-25528-000
1	69	NUTS, ACORN (MOTOR MTG.) (BAG OF 4)	363-90117-000
1	70	PLUG, ELECTRICAL HARNESS (2-REQ'D)	025-26387-003
*	71	CHANNEL, WIRE GUARD (2-REQ'D)	063-93734-000

\* NOT SHOWN

**AIR MOVING (VENTOR)**

FIG	ITEM	DESCRIPTION	D2CG120N16550A
			5-BURNER
*	72	VARISTOR (VENTOR MOTOR PROTECTOR)	025-30145-000
1	73	HOUSING, VENTOR (W / O WHEEL)	063-90041-000
*	74	PLATE, VENTOR ORIFICE	063-90038-015
*	75	PLATE, VENTOR HOUSING	063-90037-000
4	76	SPACER, VENTOR MOTOR (4-REQ'D)	063-92626-000
*	77	WHEEL, VENTOR BLOWER	026-25530-001

**REFRIGERANT**

FIG	ITEM	DESCRIPTION	D2CG120N16550A
			5-BURNER
2	78	COIL, COND. (FRONT FORMED, SYSTEM 1) (6)	363-94985-700
2	79	COIL, COND. (REAR FORMED, SYSTEM 2) (6)	363-94986-700
4	80	COIL, EVAPORATOR (SYSTEM 1 & 2) (7)	373-06378-700
	81	SPACE FOR FUTURE PARTS ADDITIONS	
	82	SPACE FOR FUTURE PARTS ADDITIONS	
*	83	VALVE, CORE	022-02475-000
*	84	CAP, FLARE	023-11018-000
4	85	STRAINER, DRIER (2-REQ'D)	029-17738-000
4	86	VALVE, DISTR. (ASSEM.) (EVAP.) (2-REQ'D)	022-06846-008
	87	SPACE FOR FUTURE PARTS ADDITIONS	
*	88	VALVE EXPANSION (EVAP.) (2-REQ'D)	022-06858-002
*	89	SPACE FOR FUTURE PARTS ADDITIONS	

**FABRICATED PARTS**

FIG	ITEM	DESCRIPTION	D2CG120N16550A
			5-BURNER
*	90	BRACKET, FILTER (TOP OR BOTTOM)	029-20069-000
*	91	BRACKET, FILTER (MIDDLE)	029-20070-000
*	92	COVER, DUCT (SUPPLY AIR)	363-90060-001
4	93	COVER, DUCT (OUTSIDE AIR)	363-90060-002
*	94	COVER, DUCT (RETURN AIR)	363-90060-003
*	95	COVER, DUCT (BASE HEAT SECT.)	363-89934-000
*	96	COVER, DUCT (BASE, EVAP)	363-89941-000
4	97	HOOD, AIR INLET (W / O SCREEN)	063-75440-000
4	98	SCREEN, AIR INLET	026-31402-000
4	99	HOOD, FLUE OUTLET (W / SCREEN)	363-93855-000
4	100	PAN, DRAIN	363-93501-000
4	101	PANEL, CORNER (LEFT FRONT)	363-90056-000
4	102	PANEL, ACCESS (BLOWER)	363-89927-002
4	103	PANEL, ACCESS (CONTROL BOX)	363-89937-001
4	104	PANEL, ACCESS (GAS TOP)	063-89966-002
4	105	PANEL, ACCESS (GAS BOTTOM)	063-89985-000
4	106	PANEL, DUCT (REAR)	363-90051-002
4	107	PANEL, ACCESS (FILTERS)	363-89927-002
4	108	PANEL, ACCESS (COMPRESSOR)	063-90070-002
4	109	PANEL, TOP (CONDENSER)	063-90013-000
4	110	PANEL, TOP (EVAPORATOR)	363-94624-000
*	111	PANEL, VESTIBULE (FRONT)	073-03138-000
*	112	PANEL, VESTIBULE (TOP)	063-90047-000
*	113	PANEL, VESTIBULE (BOTTOM)	073-03137-000
4	114	POST (BLOWER SUPPORT)	063-92560-002
4	115	POST (INTERMEDIATE)	063-89953-002
4	116	POST (LEFT PARTITION SUPPORT)	063-89973-002

\* NOT SHOWN

(6) INCLUDES HEADERS.

(7) INCLUDES HEADERS, DISTRIBUTORS W/TUBES, & EXPANSION VALVES.

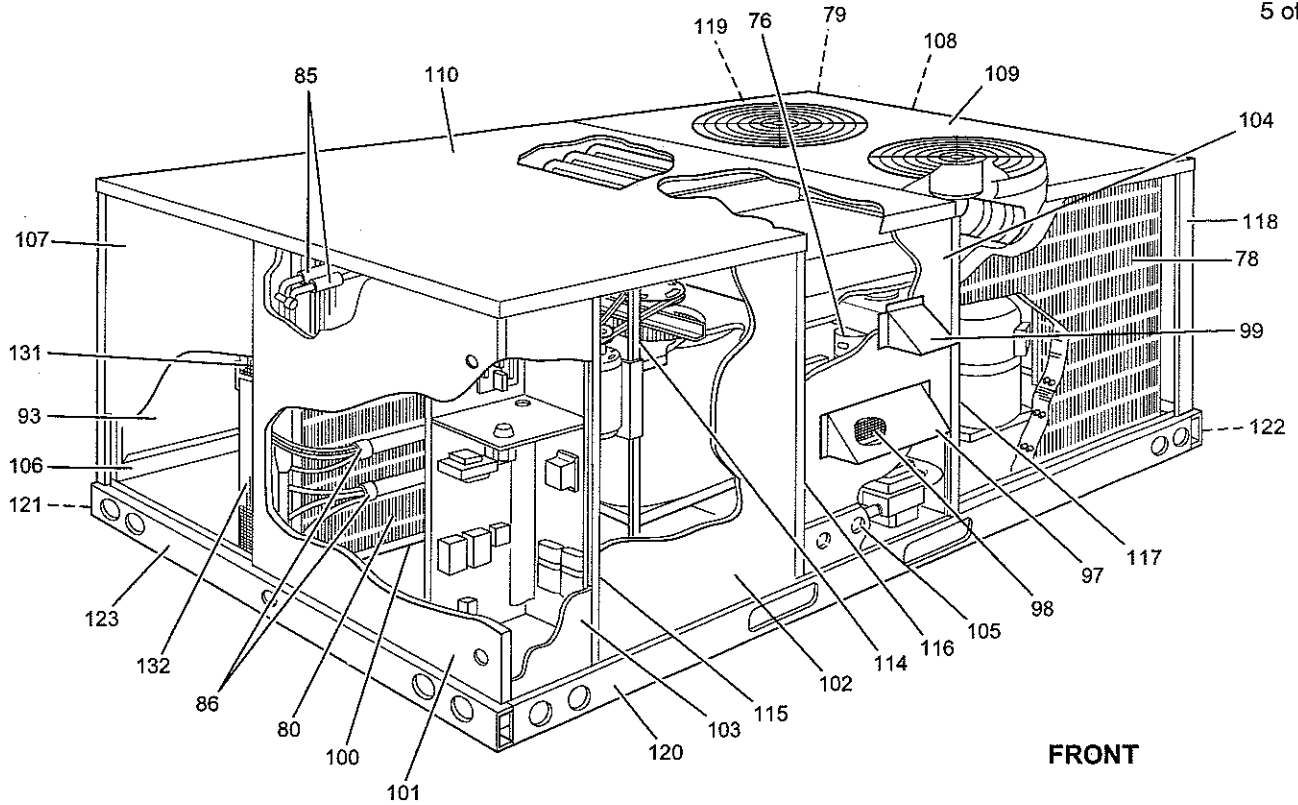

**FIG. 4 – SINGLE PACKAGE GAS / ELECTRIC UNIT**

**FABRICATED PARTS (Cont.)**

FIG	ITEM	DESCRIPTION	D2CG120N16550A
			5-BURNER
4	117	POST (RIGHT PARTITION SUPPORT)	063-89987-002
4	118	POST, CORNER ( RIGHT FRONT)	063-89994-002
4	119	POST, CORNER (RIGHT REAR)	063-89995-002
4	120	RAIL, BASE (FRONT)	063-90014-000
4	121	RAIL, BASE (REAR)	063-90015-000
4	122	RAIL, BASE (COND. END)	063-90011-000
4	123	RAIL, BASE (EVAP. END)	063-94720-000

**RELIEF/FIXED AIR DAMPER HOOD**

FIG	ITEM	DESCRIPTION	D2CG120N16550A
			5-BURNER
5	124	ASSEMBLY, COMPLETE HOOD	363-89962-000
5	125	PANEL, TOP	063-87680-000
5	126	PANEL, RIGHT SIDE	063-87659-000
5	127	PANEL, LEFT SIDE	063-87686-000
5	128	SUPPORT, BLADE	063-89961-000
5	129	BLADE, DAMPER	029-20071-000
5	130	WIRE, CLOTH (1 X 2 MESH)	026-31400-000

**MISC.**

FIG	ITEM	DESCRIPTION	D2CG120N16550A
			5-BURNER
4	131	FILTER, AIR (2-REQ'D)	18 x 24 x 2
4	132	FILTER, AIR (2-REQ'D)	16 x 24 x 2
*	133	BUSHING (8)	025-26385-000
*	134	ELBOW, 90 DEG. (8)	023-13649-000

\* NOT SHOWN

(8) ELBOW 023-13649-000 IS HELD IN PLACE ON DRAIN PAN WITH BUSHING 025-26385-000.

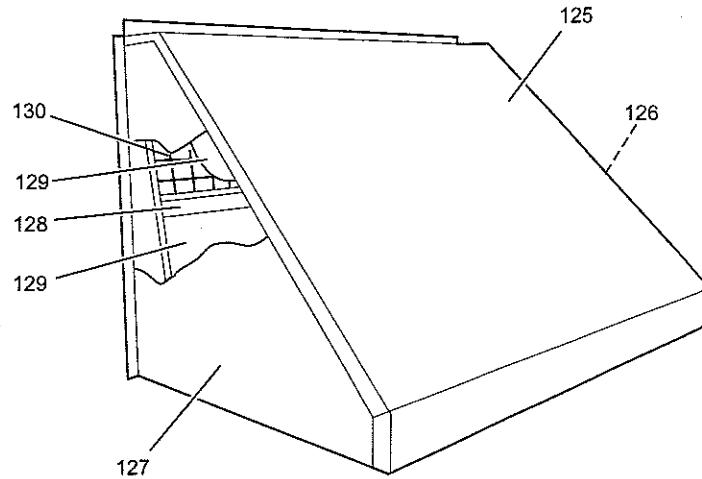

**FIG. 5 – RELIEF / FIXED AIR DAMPER HOOD ASSEMBLY  
(ITEM 124)**

NOTE: **STYLE "B"** MODELS WERE NEVER PRODUCED

NOTE: **STYLE "C"** MODELS ARE THE SAME AS **STYLE "A"** EXCEPT FOR THE FOLLOWING PARTS:

FIG	ITEM	DESCRIPTION	D2CG120N16550C
2	3	ISOLATOR, COMPRESSOR	OMIT
2	4A	ISOLATOR, COMPR. TOP (8-REQ'D)	028-11969-000
2	4B	ISOLATOR, COMPR. BOTTOM (8-REQ'D)	028-12357-000
2	4C	SPRING, MTG. COMPR. (8-REQ'D)	029-20421-000
2	4D	SCREW, 5/16-18 HEX WASHER HD. W/SLEEVE	021-17181-700
1	(28)	RELAY, CONTROL (HEAT SEQUENCE) [TDR]	024-19082-738
*	76	WHEEL, VENTOR BLOWER	026-32624-000

NOTE: **STYLE "D"** MODELS ARE THE SAME AS **STYLE "C"** EXCEPT FOR THE FOLLOWING PARTS:

FIG	ITEM	DESCRIPTION	D2CG120N16550D
1	(7)	MOTOR, VENTOR	<b>024-24115-016</b>
*	46	CONTROL, TEMPERATURE (ROLLOUT)	<b>025-26392-010</b>
*	(47)	CONTROL, IGNITION [IC]	<b>025-29012-001</b>
*	45	CONTROL, TEMPERATURE (LIMIT)	<b>025-26366-008</b>
*	25	LABEL, WIRING (REFERENCE)	035-13391-000
1	(27)	RELAY, CONTROL [DMR]	024-25910-700
1	(28)	RELAY, CONTROL (HEAT SEQUENCE) [TDR]	024-19082-740
*	72	VARISTOR	OMIT
*	10	BOOT, RUBBER CAPACITOR	OMIT
1	120	RAIL, BASE (FRONT)	063-90014-001
1	121	RAIL, BASE (REAR)	063-90015-001
1	122	RAIL, BASE (COND. END)	<b>063-90011-001</b>

\* NOT SHOWN

New replacement parts shown in **bold face** type at the first printing of parts List code dated 5/96.

# NOTES

# NOTES



Heating and Air Conditioning

Unitary Products Group  
P.O. Box 1592, York, Pennsylvania USA 17405-1592  
Subject to change without notice. Printed in U.S.A.  
Copyright © by York International Corporation 1996. All rights reserved.

RPC 2M 596 .44

CODE: RBYE

530.18-RP5.2YI





**REPLACEMENT PARTS**

Supersedes: SEE BELOW

e 530.18-RP5.3YI (596)

SUPERSEDES: 530.18-RP2.13YI (1192), ERRATA 1 (595) PAGE 6.  
NOTE: FOR STYLE "B" THRU "D" MODELS SEE PAGE 6.

1 of 8

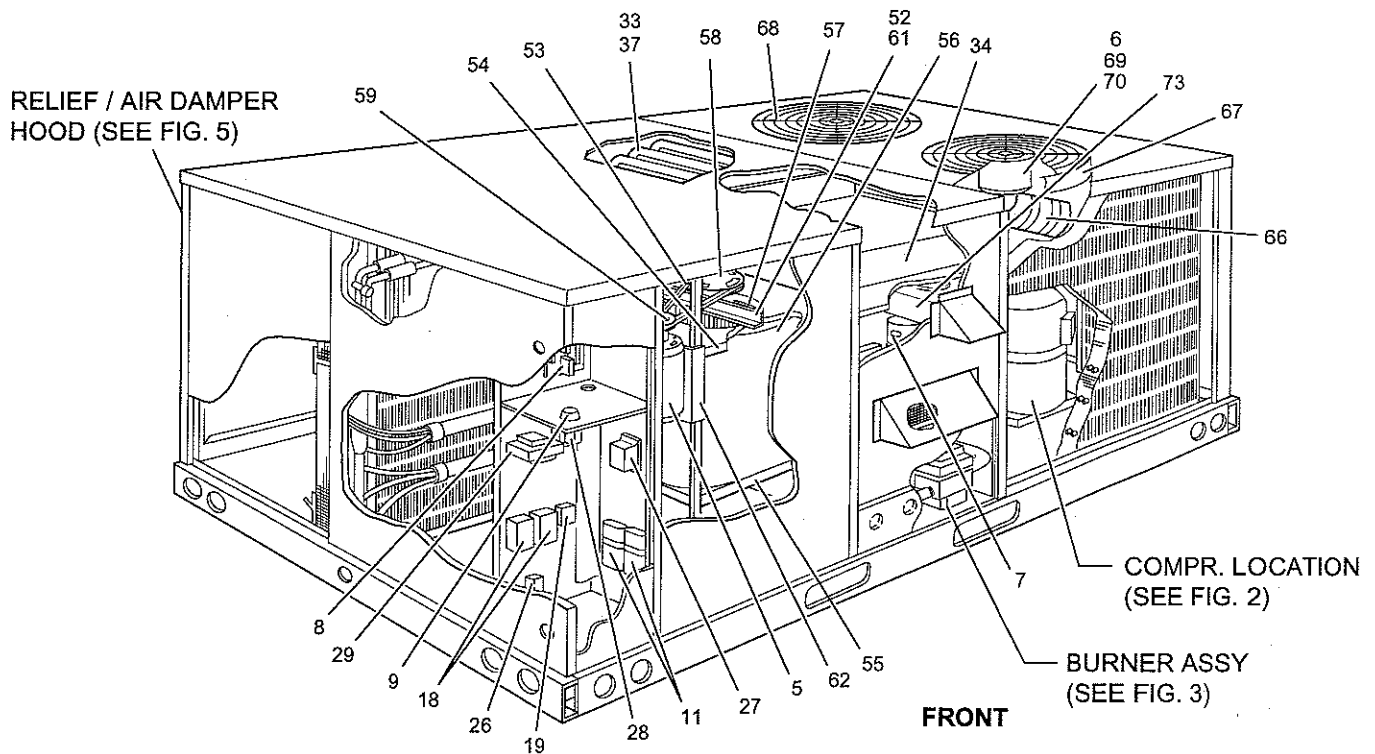

**FIG. 1 – SINGLE PACKAGE GAS / ELECTRIC UNIT**

**COMPRESSORS**

FIG	ITEM	DESCRIPTION	D2CG150N16550A
			5-BURNER
2	(1)	COMPRESSOR, HERMETIC (SYSTEM 1)	015-02120-002
2	(2)	COMPRESSOR, HERMETIC (DUAL) (SYSTEM 2)	015-02047-001
2	3	ISOLATOR, COMPR. (DUAL) (6-REQ'D)	028-12342-700
2	3A	SCREW, 5/16-18 HEX WASHER HD. W/SLEEVE	021-16803-000
2	4A	ISOLATOR, COMPR. (4-REQ'D TOP) SYS. 1	028-12357-000
2	4B	ISOLATOR, COMPR. (4-REQ'D BOTTOM) SYS. 1	028-11969-000
2	4C	SPRING, MTG. COMPR. (4-REQ'D) SYS. 1	029-20421-000
2	4D	SCREW, 5/16-18 HEX WASHER HD. W/SLEEVE	021-17181-700

**MOTORS**

FIG	ITEM	DESCRIPTION	D2CG150N16550A
			5-BURNER
1	(5)	MOTOR, BLOWER (3.0 HP)	024-24137-701
1	(6)	MOTOR, FAN (2-REQ'D)	024-24110-704
1	(7)	MOTOR, VENTOR (1)	024-24115-712

**ELECTRICAL**

FIG	ITEM	DESCRIPTION	D2CG150N16550A
			5-BURNER
1	8	BOARD, CIRCUIT	031-00652-700
1	9	BREAKER, CIRCUIT [CB]	024-24055-000

\* NOT SHOWN

(1) INCLUDES CENTRIFUGAL SWITCH.

Major components and suggested stocking items are shown with item number in parenthesis "( )".